



특징 (Character)

- Dual piston구조로 파지력 극대화
High gripping forces by the structure of synchronized dual piston
- Piston, Body의 알루미늄화로 초소형, 경량화 실현
Body & parts made of aluminium alloy-Compact & Light weight gripper
- DUST COVER 일체화로 이물질 혼입방지 가능
A dust cover to prevent coarse particle
- 개폐 검출용 마그네틱 센서 부착가능
Magnetic sensor is available for open-close sensing



링크레버 방식 (Link lever type)

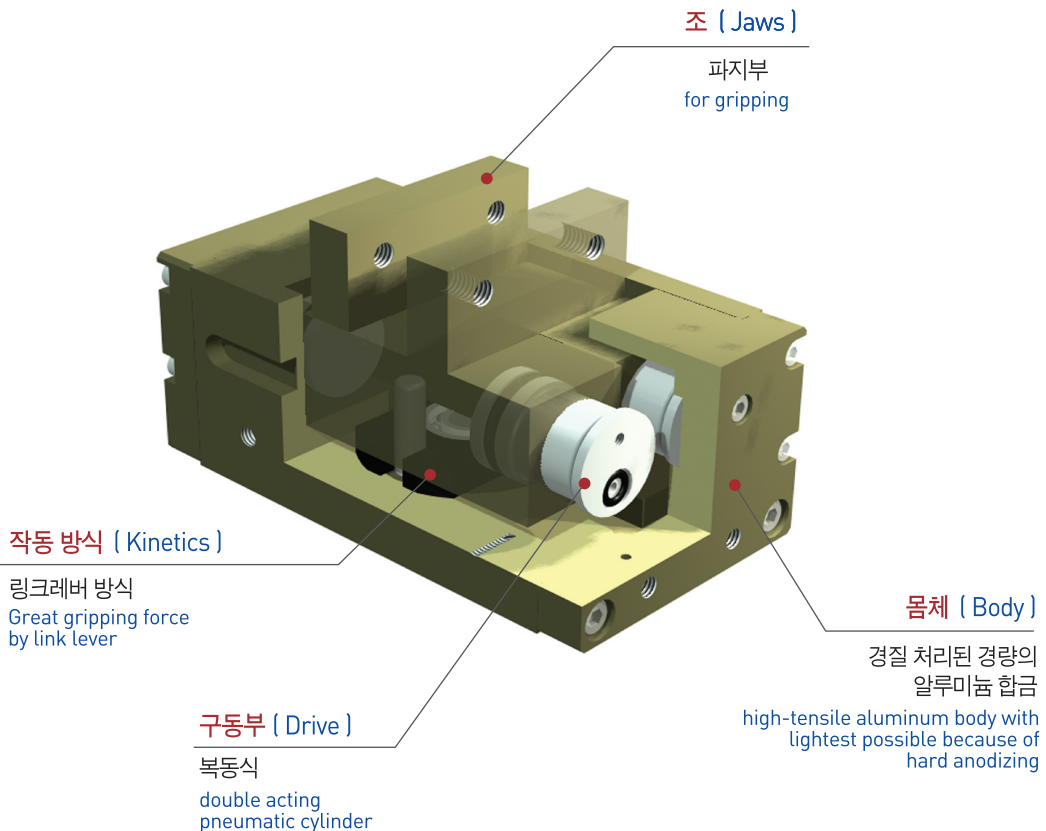

부품분해도 (Exploded view)

※ 본 분해도는 한 제품을 예시하였으므로 기종별로 차이가 있을 수 있습니다
 ※ This exploded view illustrates a certain product only. The contents may vary by product models.

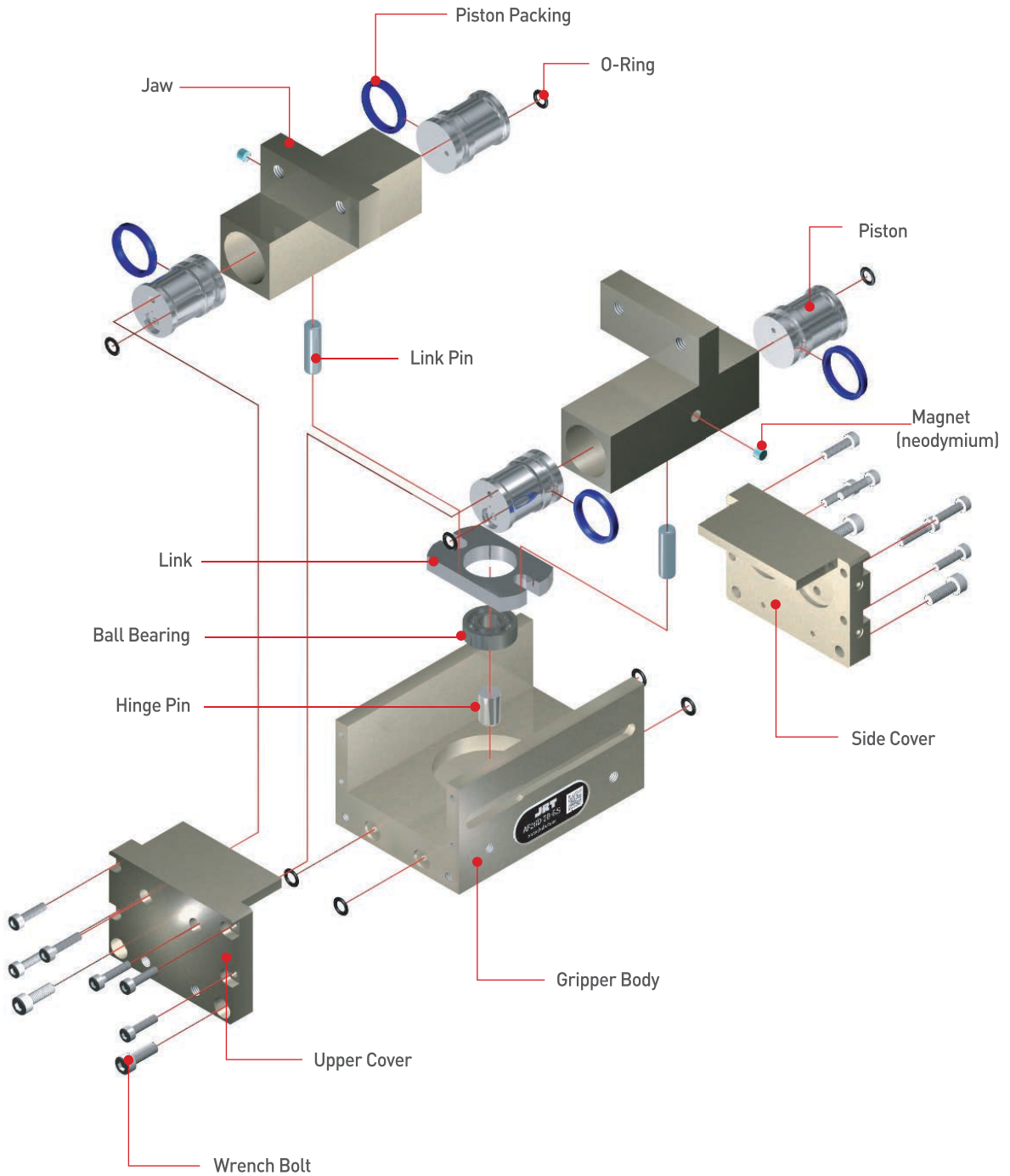

AF101
AF02
AF03
AF04P
AF105P
AF06
AF10
AF13
AF13C
AF14
AF15
AF316
AF17
AF117
AF19
AF24
AF26
AF28D
AF30
AF30L
AF30SP
AF40
AF46
AF56N
RAF56N
MF16

주문기호 (Ordering Code)

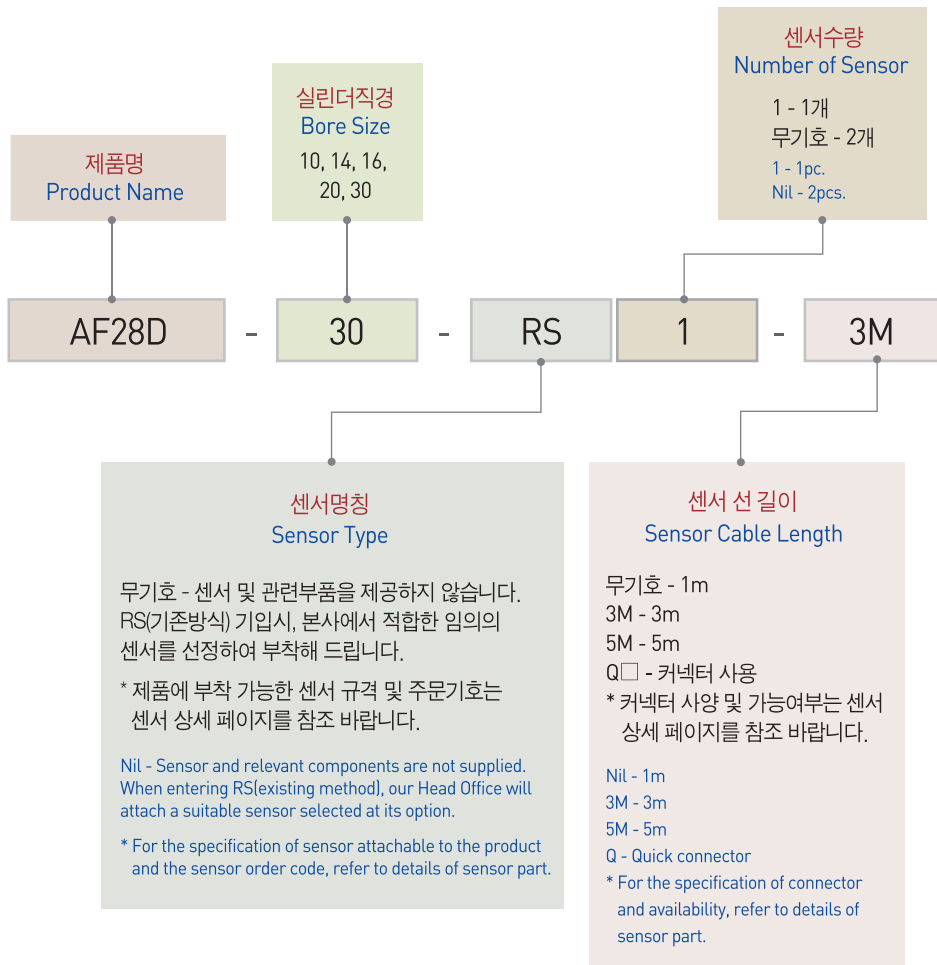

☐ 제품사양 (Specification)

P=공기압력(bar) , L=작용점까지의 거리(mm)
P=Air Pressure(bar) , L=Exertion length(mm)

제품명칭 Products Name	AF28D-10	AF28D-14	AF28D-16	AF28D-20	AF28D-30	단위 Unit
개폐범위 Stroke	15	20	24	30	36	mm
제품중량 Weight	0.19	0.3	0.42	0.8	1.57	kg
최대치구길이 Max. length attach	20	30	40	60	80	mm
배관접속구 Fitting size	M5	M5	M5	M5	M5	
파지력 : 열림시 Gripping force : Open	2.85P/(1+0.039L)	6.28P/(1+0.03L)	8.14P/(1+0.026L)	18.14P/(1+0.026L)	31.00P/(1+0.016L)	N
파지력 : 닫힘시 Gripping force : Close	2.85P/(1+0.039L)	6.28P/(1+0.03L)	8.14P/(1+0.026L)	18.14P/(1+0.026L)	31.00P/(1+0.016L)	N
1사이클당 공기소모량 Air consumption per cycle	2.4	6.2	9.7	18.8	50.9	cm ³
닫힘시/열림시 시간 Closing / Opening time	0.02/0.02	0.03/0.03	0.03/0.03	0.04/0.04	0.05/0.05	sec
반복정밀도 Repeat accuracy	0.03	0.03	0.03	0.03	0.03	mm
연속사용회수 Continuation usage amount	60	60	60	40	40	cpm
사용압력 Operating pressure	3~7					bar
주위온도 Ambient temperature	-5 to 60					℃
윤활 Lubrication	불필요 Needless					

반복정밀도 : 연속 100회 작동후 측정치
After 100 consecutive strokes to end positions

☐ 작용점에서의 파지력 (Gripping Force From a Point of Action)

범례 (Legend) : ■ 7[bar] ■ 5[bar] ■ 3[bar]

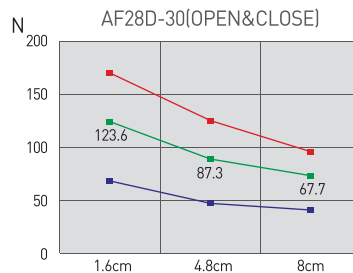
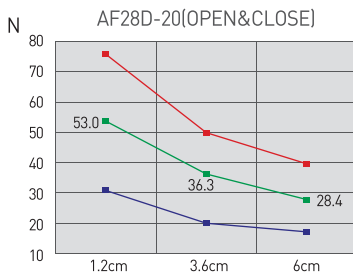
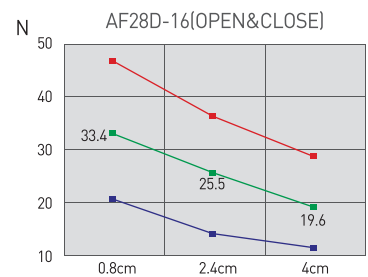
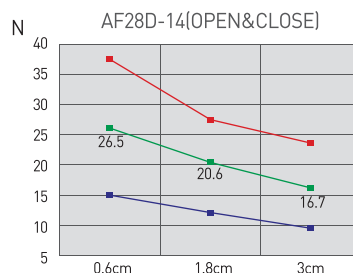
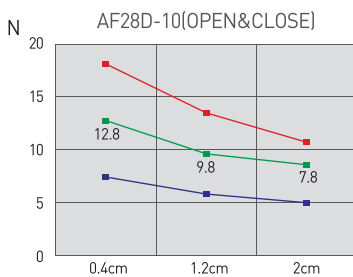

- AF101
- AF02
- AF03
- AF04P
- AF105P
- AF06
- AF10
- AF13
- AF13C
- AF14
- AF15
- AF316
- AF17
- AF117
- AF19
- AF24
- AF26
- AF28D**
- AF30
- AF30L
- AF30SP
- AF40
- AF46
- AF56N
- RAF56N
- MF16

AF28D-10

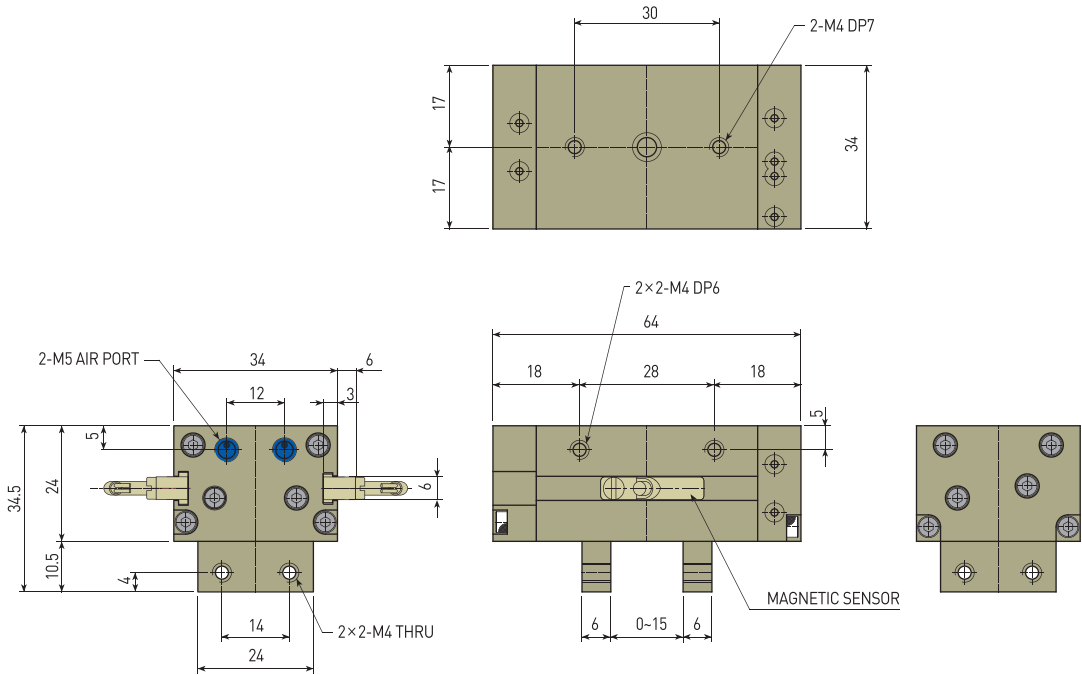

AF28D-14

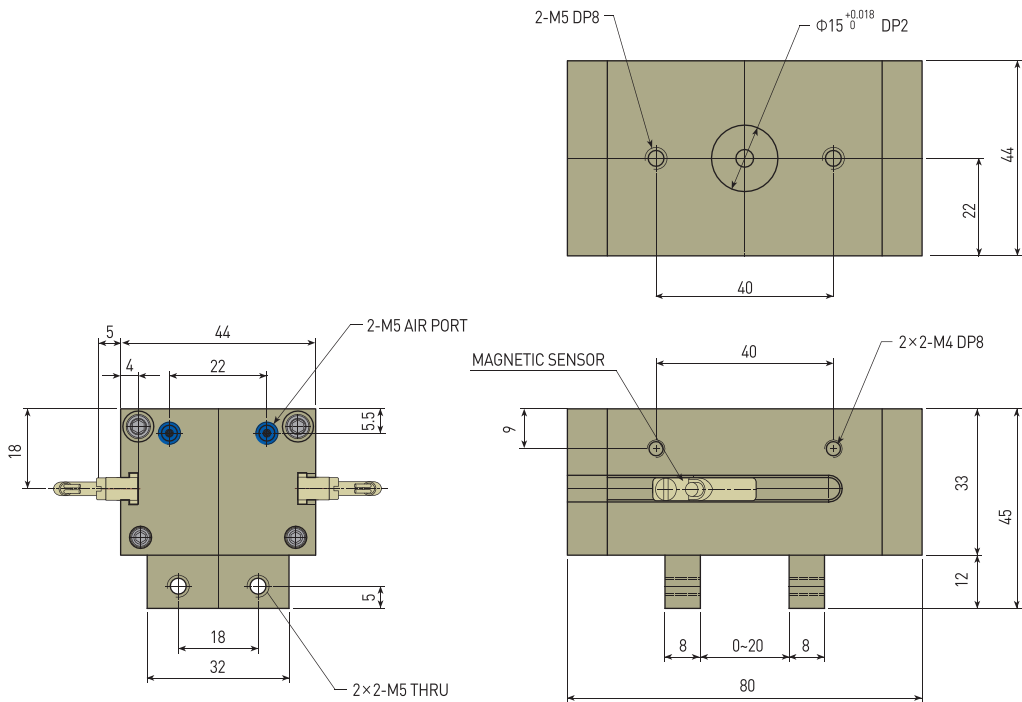

AF28D-16

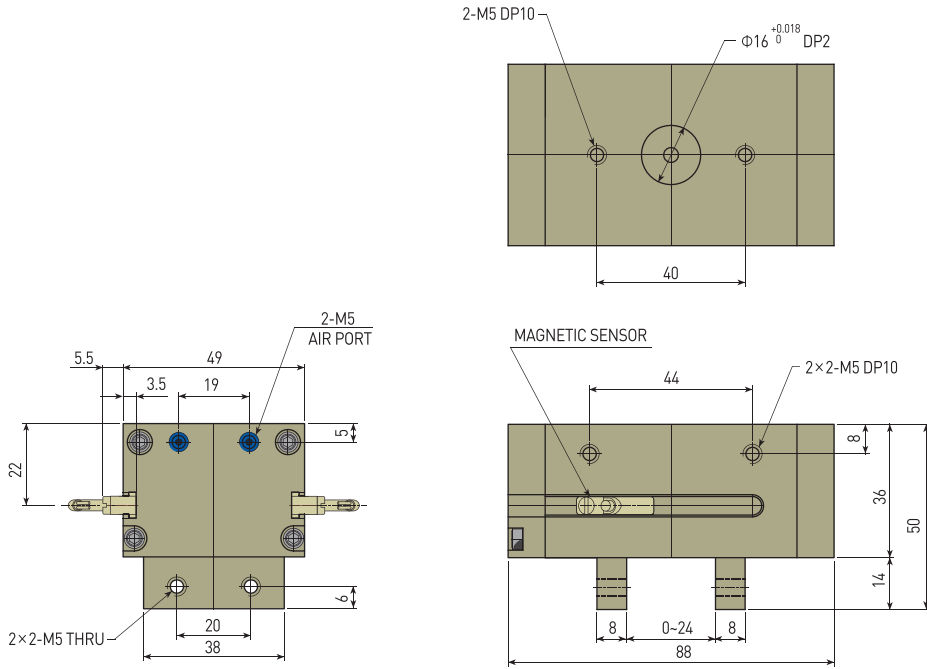

AF28D-20

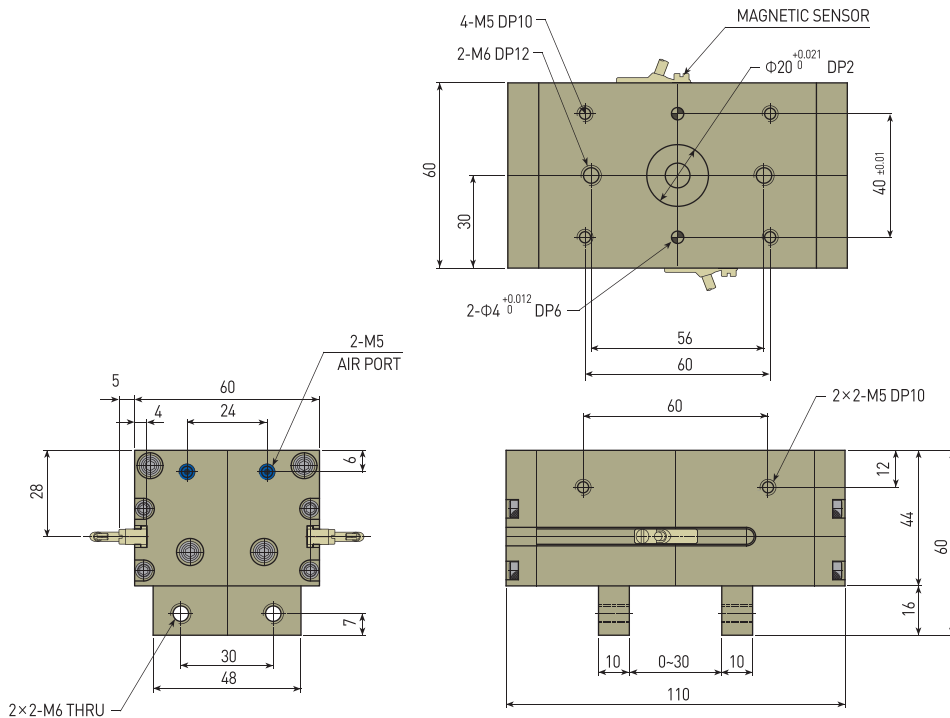

- AF101
- AF02
- AF03
- AF04P
- AF105P
- AF06
- AF10
- AF13
- AF13C
- AF14
- AF15
- AF316
- AF17
- AF117
- AF19
- AF24
- AF26
- AF28D**
- AF30
- AF30L
- AF30SP
- AF40
- AF46
- AF56N
- RAF56N
- MF16

AF28D-30

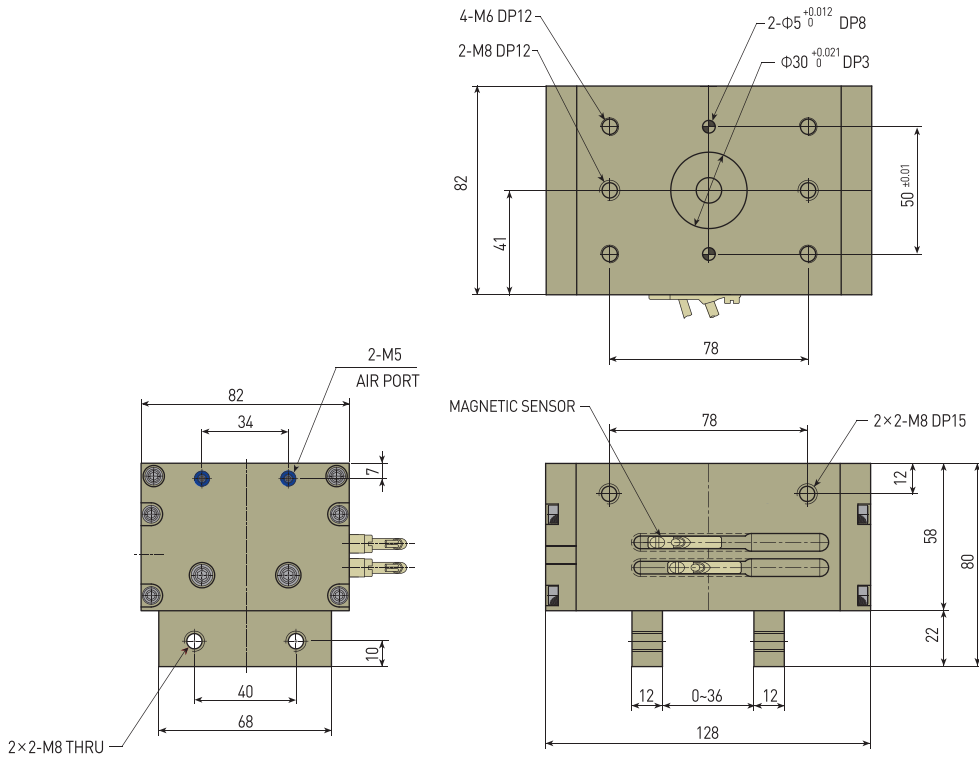

NOTE